

ALFA1035E1HDS

Family	Ovens
Subfamily	Convection oven 10 trays EN 600x400 mm or GN1/1
Oven type	Fan with humidification
Oven control	Electronic
Trays capacity	10 trays 600x400 mm - GN1/1
Power supply	400 V 3N~ / 23A / 16 kW / 50-60 Hz
Steam generation	Direct
WiFi connection	Not available
Maximum depth with open door	1536 mm
Adjustable feet	Yes
Net weight	102.000 kg
Product dimensions WxDxH	798x772x1100 mm
EAN code	8017709322953

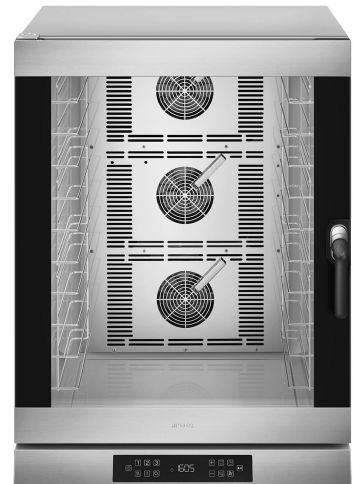

Distribution

Solutions	Bars/Cafes; Hotels; Restaurants/Catering; Bakery/Pastry making; Industrial pastry&bakery laboratories; Butcher's shops	Suggested for	Bars/Cafes
------------------	---	----------------------	------------

Aesthetics





Colour	Stainless steel	Digit display color	White
Door with stainless steel stripes	Yes	Front panel	Yes
Display type	Yes	Logo	Smeg printed

Controls

Recipes number	100	Chimney regulation	On/off
Timer setting range	1 minute -99h + endless	Haccp data	Scheduled start H/12
Cooking steps	3 + pre-heating		

Programs / Functions

Backing functions

-  Fan forced
-  Fan forced with humidification
-  Core temperature probe baking
-  Core probe + Δ t

Adjustable fan speed:

-  Adjustable fan speed

Options

Right hand hinge	ALFA1035E1HDS	Solutions	K4610X
Right hand hinge	ALFA1035EHDSR		

Construction

Oven materials	Ever Clean enamel	Water injection on each fan	Yes
Cavity dimensions (lxdxh)	672x437x854mm	Humidification levels	3 + manual
Gross volume	616x431x340mm	Exhaust position	Back
Net volume	616x431x340mm	Components cooling system	Yes
Internal net volume	616x431x340mm	Timer type	Electronic timer
Cavity material	Stainless steel	Temperature range	50-280°C
Shelves number	10	End cooking signal	Yes
Tray frame support	Chrome	Manual reset safety thermostat	Yes
Shelves distance	77 mm	Predisposition for core probe Δ t	Yes
Door construction	Double glass	Removable deflector	Yes
Door opening	Lateral	Lighting	3 Halogen lamps
Handle type	New ergonomics	Light power	40 W
Openable glass	Openable	USB port	Si
Fan type and number	3 contrarotating fans with time direction reversal	Water load pipe	Yes
Engine speed	200W	Power cable length	170 cm
Engine speed	2	Back panel	Galvanized
Max standard speed motor rpm	2	IPX protection	Scheduled start H/12
Low speed rpm	2		

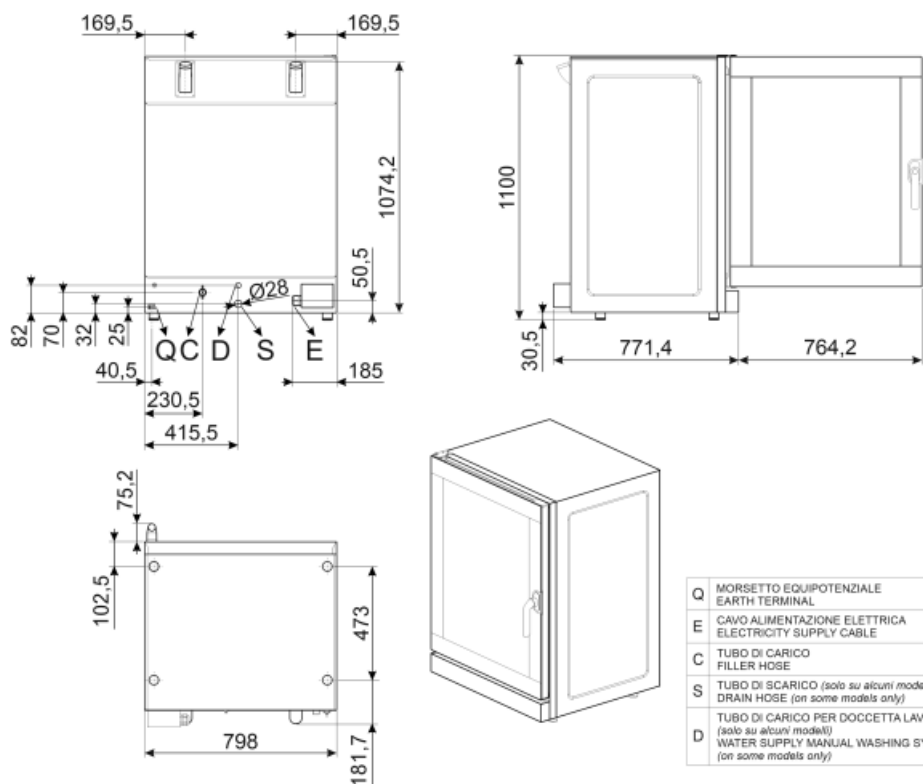

Q	MORSETTO EQUIPOTENZIALE EARTH TERMINAL
E	CAVO ALIMENTAZIONE ELETTRICA ELECTRICITY SUPPLY CABLE
C	TUBO DI CARICO FILLER HOSE
S	TUBO DI SCARICO (solo su alcuni modelli) DRAIN HOSE (on some models only)
D	TUBO DI CARICO PER DOCCETTA LAVAGGIO (solo su alcuni modelli) WATER SUPPLY MANUAL WASHING SYSTEM (on some models only)

Not included accessories



3805

Flat chrome-plated wire grid



3927

Air flow reducer kit



K4610X

TF11XH2

Perforated aluminium GN1/1 tray for Galileo professional



3743

Flat aluminium tray

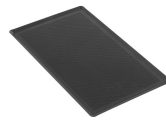

TMF11TH2

GN 1/1 non-sticking microperforated tray



T11XH20

2cm height aluminium GN1/1 tray for Galileo professional



T11XH65

6,5cm height aluminium GN1/1 tray for Galileo professional



T11TH20

2cm height GN1/1 non-stick tray for Galileo professional

KITSC

Lower and upper shelf kit



3751

Flat perforated aluminium tray

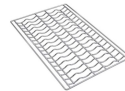

3810

Corrugated grid for baguettes

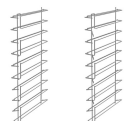

RGN11-1035-2

T11TH40

4cm height GN1/1 non-stick tray for Galileo professional



TVL625D

Oven stand on castors for stacked ALFA625 or ALFA625/420, 800x800x300mm

Symbols glossary (TT)



...



Core probe + Δt



...



...



Double speed fan