

ALFA625E1HDS

Family	Ovens
Subfamily	Convection oven 6 trays en 600x400 mm or GN1/1
Oven type	Fan with humidification
Oven control	Electronic
Trays capacity	6 trays 600x400 mm - GN1/1
Power supply	400 V 3N~ / 16 A / 10,5 kW / 50-60 Hz
Steam generation	Direct
WiFi connection	Not available
Maximum depth with open door	1521 mm
Adjustable feet	Yes
Net weight	77.000 kg
Product dimensions WxDxH	798x757x793 mm
EAN code	8017709322946



Distribution

Solutions	Bars/Cafes; Hotels; Restaurants/Catering; Bakery/Pastry making; Industrial pastry&bakery laboratories; Butcher's shops	Suggested for	Bars/Cafes
------------------	--	----------------------	------------

Aesthetics





Colour	Stainless steel	Digit display color	White
Door with stainless steel stripes	Yes	Front panel	Yes
Display type	Yes	Logo	Smeg printed

Controls

Recipes number	100	Chimney regulation	On/off
Timer setting range	1-60 minutes + endless	Haccp data	Scheduled start H/12
Cooking steps	3 + pre-heating		

Programs / Functions

Backing functions

-  Fan forced
-  Fan forced with humidification
-  Core temperature probe baking
-  Core probe + Δ t

Adjustable fan speed:

-  Adjustable fan speed

Options

Right hand hinge	ALFA1035EHDSR	Solutions	K4610X
------------------	---------------	-----------	--------

Construction

Oven materials	Ever Clean enamel	Water injection on each fan	Yes
Cavity dimensions (lxdxh)	672x437x546mm	Humidification levels	3 + manual
Gross volume	460x360x425mm	Exhaust position	Back
Net volume	460x360x425mm	Components cooling system	Yes
Internal net volume	460x360x425mm	Timer type	Electronic timer
Cavity material	Stainless steel	Temperature range	50-280°C
Shelves number	6	End cooking signal	Yes
Tray frame support	Chrome	Manual reset safety thermostat	Yes
Shelves distance	77 mm	Predisposition for core probe Δ t	Yes
Door construction	Double glass	Removable deflector	Yes
Door opening	Lateral	Lighting	2 LED lamps
Handle type	New ergonomics	Light power	40 W
Openable glass	Openable	USB port	Si
Fan type and number	2 contrarotating fans with time direction reversal	Water load pipe	Yes
Engine speed	200W	Power cable length	170 cm
Engine speed	2	Back panel	Galvanized
Max standard speed motor rpm	2	IPX protection	Scheduled start H/12
Low speed rpm	2		

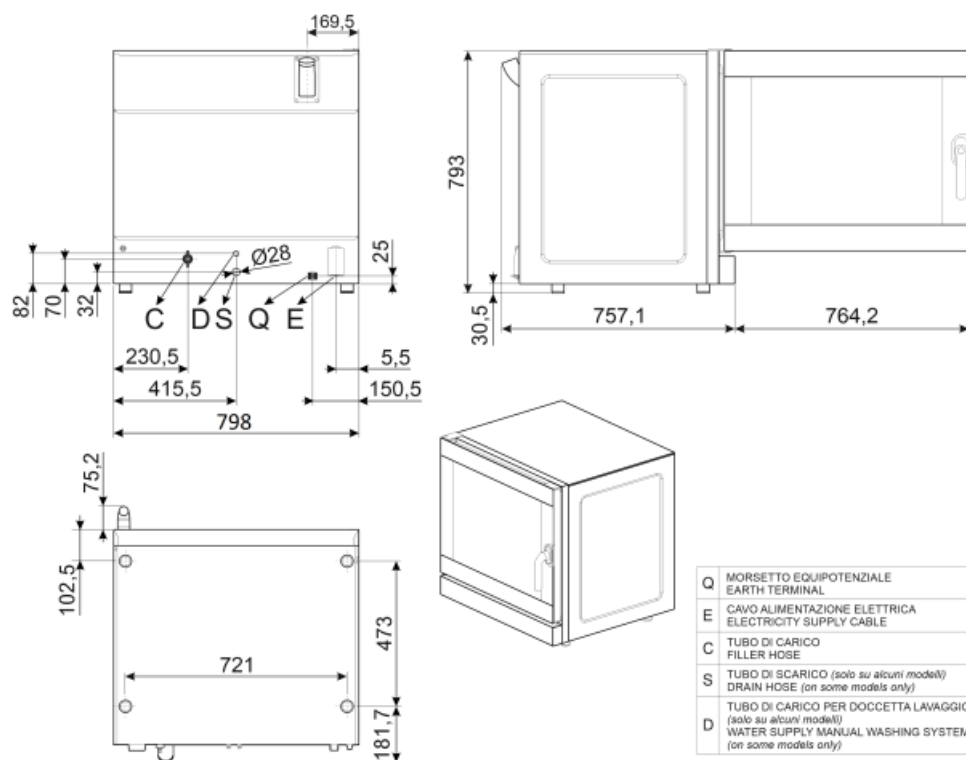

Q	MORSETTO EQUIPOTENZIALE EARTH TERMINAL
E	CAVO ALIMENTAZIONE ELETTRICA ELECTRICITY SUPPLY CABLE
C	TUBO DI CARICO FILLER HOSE
S	TUBO DI SCARICO (solo su alcuni modelli) DRAIN HOSE (on some models only)
D	TUBO DI CARICO PER DOCCETTA LAVAGGIO (solo su alcuni modelli) WATER SUPPLY MANUAL WASHING SYSTEM (on some models only)

Not included accessories



3805
Flat chrome-plated wire grid



3927
Air flow reducer kit

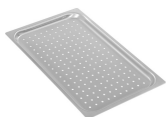

TF11XH2
Perforated aluminium GN1/1 tray for Galileo professional

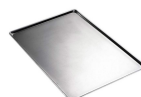

3743
Flat aluminium tray

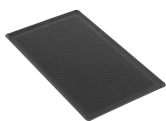

TMF11TH2
GN 1/1 non-sticking microperforated tray

SVRPP625
Conjunction kit for 2 ovens series 625/420 and hood



T11XH20
2cm height aluminium GN1/1 tray for Galileo professional



SVRPP420-625
Connector kit for two stacked ALFA420+420 or ALFA420+625 models and hood



T11XH65
6,5cm height aluminium GN1/1 tray for Galileo professional



T11TH20
2cm height GN1/1 non-stick tray for Galileo professional

KITSC
Lower and upper shelf kit

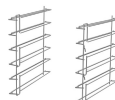

RGN11-625-2



3751
Flat perforated aluminium tray

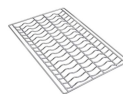

3810
Corrugated grid for baguettes



T11TH40
4cm height GN1/1 non-stick tray for Galileo professional

Symbols glossary (TT)



...



Core probe + Δt



...



...



Double speed fan