



**Goldstein**

## 800 SERIES GAS CHARGRILLS

BQG12-X



### Standard features and benefits

- Heavy duty welded stainless steel body for rigidity and durability
- Fully welded surrounds
- 2x 20 MJ Inline radiant burners per every 305mm section
- 2 char pattern options on reversible cooking grates
- 2 levelling options - flat or gradient
- Constant pilot flame, maximises operating and energy efficiency
- Pilot flame failure on burners
- Front grease trough, generous chute and catcher
- Stainless steel fascia and sides and spill zone for ease of cleaning
- Large, heat resistant reinforced control knob with easy to view settings and high to low flame control
- Adjustable legs 140-170mm
- Easy to service



### Other options

- Ceramic rocks option available to increase heat retention and flavour
- Bench mounted
- Stand with undershelf



Cert. No.  
AGA 7732



**MIDDLEBY GOLDSTEIN**

1800 013 123 | +61 2 9604 7333  
sales@middleby.com.au  
middleby.com.au

**VIC - TAS** - 47 Stubbs Street, Kensington VIC 3031  
**QLD** - U12, 210 Queensport Rd Nth, Murarrie QLD 4172  
**WA** - U2, 9 Meares Way, Canning Vale WA 6155

**HEAD OFFICE  
AND MANUFACTURING PLANT**  
211-217 Woodpark Road, Smithfield NSW 2164

v1\_2024



**BQG12-X**

# 800 SERIES GAS CHARGRILLS

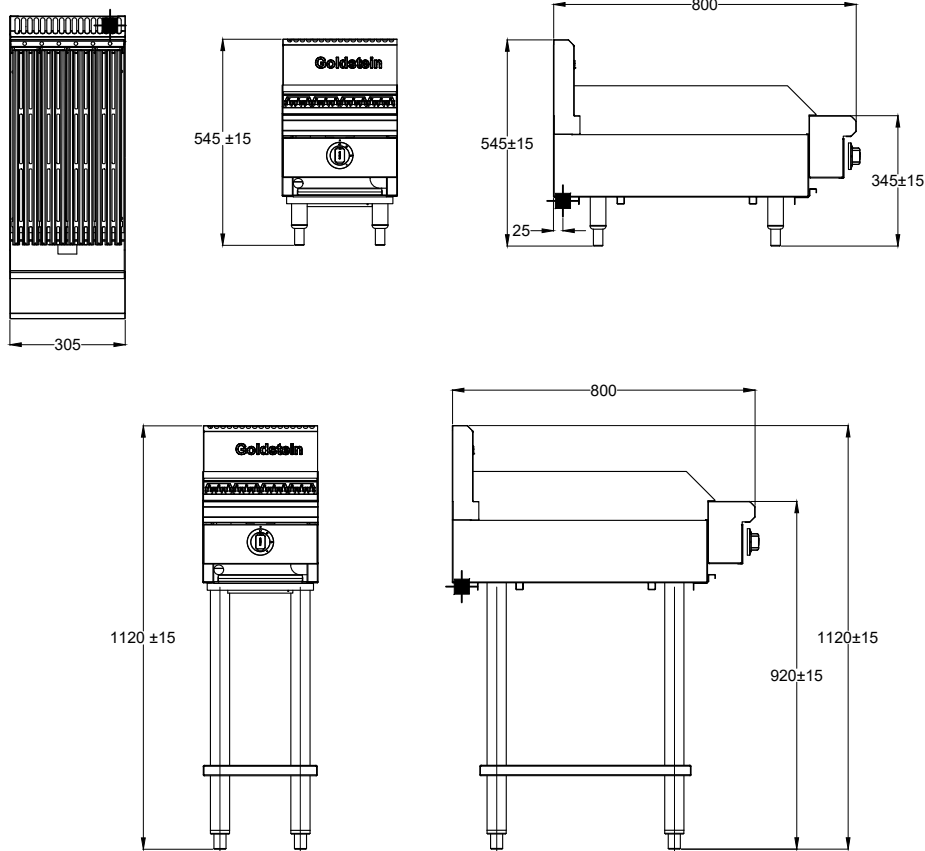

■ 3/4" BSP Gas Connection

## SPECIFICATIONS

<b>Dimensions (WxDxH)</b>	bench mounted	305 x 800 x 545 mm
	on stand	305 x 800 x 1120 mm
<b>Grill size</b>		305 x 510 mm

<b>Gas connection</b>	3/4" BSPM
<b>Rating NG/LPG</b>	40/38 MJ
<b>Packed dimensions without stand</b>	530 x 900 x 870 mm

Available in Natural and LP gas

## INSTALLATION CLEARANCES (minimum)

<b>Combustible Material</b>	<b>Sides</b>	250* mm
	<b>Back</b>	50 mm

<b>Non-combustible Material</b>	<b>Sides</b>	0 mm
	<b>Back</b>	0 mm

Note: \* If adjacent surface is of combustible material and is 100mm below the cooking surface, then only 50mm clearance is required.

Please note, due to ongoing product development and improvement, we reserve the right to change product design and specification at any time without notice.



**1800 013 123 | +61 2 9604 7333**  
sales@middleby.com.au  
middleby.com.au

**VIC - TAS** - 47 Stubbs Street, Kensington VIC 3031  
**QLD** - U12, 210 Queensport Rd Nth, Murarrie QLD 4172  
**WA** - U2, 9 Meares Way, Canning Vale WA 6155

**HEAD OFFICE AND MANUFACTURING PLANT**  
211-217 Woodpark Road, Smithfield NSW 2164

v1\_2024