

**apuro**

# Coffee Machine

## Instruction manual



**Model:**  
**CW305-A**

## Safety Instructions

- Position on a flat, stable surface.
- A service agent/qualified technician should carry out installation and any repairs if required. Do not remove any components on this product.
- Consult Local and National Standards to comply with the following:
  - Health and Safety at Work Legislation
  - Fire Precautions
  - IEE Wiring Regulations
  - Building Regulations
- DO NOT use jet/pressure washers to clean the appliance.
- DO NOT immerse the appliance in water.
- Do not overfill the water reservoir.
- Ensure the power cord never touches the hotplate.
- **DO NOT touch hot surfaces.**
- DO NOT touch the hotplate when the appliance is on. 
- DO NOT leave the appliance unattended during operation.
- DO NOT remove the filter basket during the filtration process.
- Never leave the empty glass jug on the hotplate when the coffee maker is on. Otherwise, the carafe is liable to crack.
- DO NOT place on or near hot surfaces such as a hob or radiant rings or near a naked flame.
- Suitable for indoor use only.
- Always switch off and disconnect the power supply to the appliance when cleaning or not in use.
- Never use accessories which are not recommended by the manufacturer. They could pose a safety risk to the user and might damage the appliance. Only use original parts and accessories.
- This appliance must only be used in accordance with these instructions and by persons competent to do so.

- This appliance is not intended for use by persons (including children) with reduced physical, sensory or mental capabilities, or lack of experience and knowledge, unless they have been given supervision or instruction concerning the use of the appliance by a person responsible for their safety.
- Children should be supervised to ensure that they do not play with the appliance.
- Keep all packaging away from children. Dispose of the packaging in accordance to the regulations of local authorities.
- If the power cord is damaged, it must be replaced by an APURO agent or a recommended qualified technician in order to avoid a hazard.
- APURO recommend that this appliance should be periodically tested (at least annually) by a Competent Person. Testing should include, but not be limited to: Visual Inspection, Polarity Test, Earth Continuity, Insulation Continuity and Functional Testing.

## Introduction

Please take a few moments to carefully read through this manual. Correct maintenance and operation of this machine will provide the best possible performance from your APURO product.

## Pack Contents

The following is included:

- APURO Filter Coffee Maker
- Filter basket
- 1.8Ltr Glass jug
- Instruction manual

APURO prides itself on quality and service, ensuring that at the time of packaging the contents are supplied fully functional and free of damage.

Should you find any damage as a result of transit, please contact your APURO dealer immediately.

## Installation

- The appliance is not suitable for installation in an area where a water jet could be used.
- Do not place the coffee maker on a highly polished wooden surface as damage may occur to the surface.

## Operation

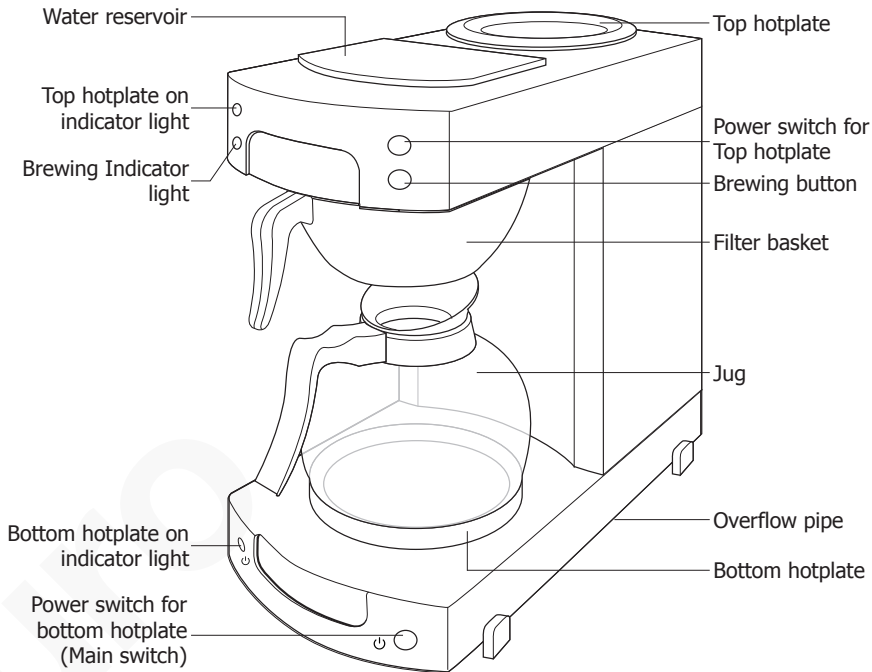

### Preparation before first use

APURO recommend that the appliance is cleaned out before using for the first time, or if the appliance has been sat unused for an extended period of time.

1. Slide the empty filter basket into position between the two basket tabs.
2. Place the jug on the bottom hotplate beneath the basket.
3. Fill the water reservoir with cold water.

**Note: Use the jug to fill the reservoir to ensure it's maximum capacity is not exceeded. The maximum amount of water the reservoir can contain is 1.8 litres. If too much water is filled, excess water will drain out through the overflow pipe.**

4. Connect to the mains power supply.
5. Turn the main switch  On. The indicator light for bottom hotplate is on.
6. Press the brewing button. The brewing indicator light illuminates and the hot water will begin to fill the jug.

**Note: During operation, steam may rise from the appliance and loud bubbling noises may be heard. This is perfectly normal.**

7. Once finished the brewing indicator light will switch off. Discard the hot water in the jug.

**WARNING: The glass jug becomes hot during operation. Always pick up the jug by the handle to avoid injury.**

8. Repeat steps 1-7. The appliance is now ready for use.

- **Caution: There is 0.5L of water remaining in the coffee maker boiler and hoses. Do not tip over after use. Also ensure to note this when the appliance is subject to freezing temperatures.**
- **Caution: If the appliance is ever drained down, ensure to repeat the above preparation steps.**

**WARNING: The surrounding surface of the hotplate may become hot. DO NOT touch! Never heat an empty Jug on the hotplate, or allow the Jug to run dry.**

**WARNING: The power switch for the bottom hotplate is the main switch. Ensure to turn it on before turning the top hotplate switch on.**

## Making Coffee

1. Place a paper filter inside the filter basket. Before this ensure the filter support already lies flat at the bottom of the basket.
2. Measure the required amount of ground coffee into the filter paper and slide the filter basket into position.
3. Place the jug on the bottom hotplate beneath the basket.
4. Fill the water reservoir with cold water.
5. Turn the main switch  On. The indicator light for bottom hotplate is on.
6. Press the brewing button. The brewing indicator light illuminates and the hot coffee will begin to fill the jug.

**Note: During operation, steam may rise from the appliance and loud bubbling noises may be heard. This is perfectly normal.**

7. Once finished the brewing indicator light will switch off.

**WARNING: The glass jug becomes hot during operation. Always pick up the jug by the handle to avoid injury.**

8. Leave the jug on the hotplate to keep warm, if required. Discard the coffee residue and filter paper from the filter basket.
9. To turn Off the hotplate, turn off the main switch .

## Using the top hotplate

This appliance is fitted with a second hotplate to keep an additional jug warm. To use:

1. Place the jug on the top hotplate.
2. Turn the power switch on for the top hotplate.
3. Ensure to turn the top hotplate off when not in use.

## Cleaning, Care & Maintenance

- **Always turn off and disconnect the appliance from the power supply before cleaning.**
- Use soapy water and a damp cloth to clean the exterior of the appliance.
- Wash the glass jug and filter basket with warm soapy water.
- Dry thoroughly after cleaning.

## Descaling

For the best water quality, Apuro recommend that a water filter is installed to the mains water supply, particularly in hard water areas. Doing so will reduce the build up of limescale and contaminants in the water tank thus maintaining energy efficiency and prolonging the life of the appliance. To descale the appliance:

1. Pour a solution of descaler and water into the reservoir.

**Use a suitable descaler and follow the manufacturer's instructions on the container.**

2. Turn the main switch  On and Press the brewing button.
3. After approximately 4 minutes turn the appliance Off to allow the descaling solution to work through the system.
4. After approximately 10 minutes turn the appliance back On. Allow the reservoir to empty.
5. Discard the solution collected in the jug.
6. Fill the reservoir with clean water and turn the appliance back On to flush out the system and remove any descaler residue. Discard the collected water and rinse the jug. Repeat with clean water 2 more times to flush out.
7. The appliance is now ready for use.

**IMPORTANT: Failure to descale or maintain will invalidate your guarantee.**

## Troubleshooting

A qualified technician should carry out repairs if required.

Fault	Probable Cause	Solution
The unit is not working	Unit not switched on	Check unit plugged in correctly and switched on
	Plug or lead is damaged	Replace plug or lead
	Mains power supply fault	Check mains power supply
	Overheating protection is activated	Consult a qualified technician
Coffee is not coming from the filter basket	No water in reservoir	Turn Off and fill reservoir
	Coffee too compact within the filter	Turn off, loosen coffee within the filter and resume
Loud noise	No water in reservoir	Turn Off and fill reservoir

## Technical Specifications

Note: Due to our continuing program of research and development, the specifications herein may be subject to change without notice.

Model	Voltage	Power	Reservoir Capacity	Dimensions h x w x d mm	Weight
<b>CW305-A</b>	230-240V~ 50-60Hz	2050-2250W	1.8 litre	435 x 205 x 380	5.42Kg

## Electrical Wiring

The plug is to be connected to a suitable mains socket.

This appliance is wired as follows:

- Live wire (coloured brown) to terminal marked L
- Neutral wire (coloured blue) to terminal marked N
- Earth wire (coloured green/yellow) to terminal marked E



This appliance must be earthed.

If in doubt consult a qualified electrician.

Electrical isolation points must be kept clear of any obstructions. In the event of any emergency disconnection being required they must be readily accessible.

## Compliance

The product must not be disposed of as household waste. To help prevent possible harm to human health and/or the environment, the product must be disposed of in an approved and environmentally safe recycling process. For further information on how to dispose of this product correctly, contact the product supplier, or the local authority responsible for waste disposal in your area.

APURO parts have undergone strict product testing in order to comply with regulatory standards and specifications set by international, independent, and federal authorities.



APURO products have been approved to carry the following symbol:

All rights reserved. No part of these instructions may be produced or transmitted in any form or by any means, electronic, mechanical, photocopying, recording or otherwise, without the prior written permission of Apuro. Every effort is made to ensure all details are correct at the time of going to press, however, Apuro reserves the right to change specifications without notice.

# DECLARATION OF CONFORMITY

- Conformiteitsverklaring • Déclaration de conformité • Konformitätserklärung • Dichiarazione di conformità •
- Declaración de conformidad • Declaração de conformidade

Equipment Type • Uitrustingstype • Type d'équipement • Gerätetyp • Tipo di apparecchiatura • Tipo de equipo • Tipo de equipamento	Model • Modèle • Modell • Modello • Modelo • Malli
Filter Coffee Maker with Glass Jug	CW305-A
Application of Territory Legislation & Council Directives(s) Toepassing van Europese Richtlijn(en) • Application de la/des directive(s) du Conseil • Anwendbare EU-Richtlinie(n) • Applicazione delle Direttive • Aplicación de la(s) directiva(s) del consejo • Aplicação de directiva(s) do Conselho	Electrical Safety IEC 60335-1:2010 +A1:2013 +A2:2016 IEC 60335-2-75:2012 +A1:2015  Electro-Magnetic Compatibility (EMC) EN IEC 55014-1:2021 EN IEC 55014-2:2021 EN IEC 61000-3-2: 2019 +A1:2021 EN 61000-3-3: 2013 +A1:2019 +A2:2021
Producer Name • Naam fabrikant • Nom du producteur • Name des Herstellers • Nome del produttore • Nombre del fabricante • Nome do fabricante	Apuro

I, the undersigned, hereby declare that the equipment specified above conforms to the above Territory Legislation, Directive(s) and Standard(s).

Ik, de ondergetekende, verklaar hierbij dat de hierboven gespecificeerde uitrusting goedgekeurd is volgens de bovenstaande Richtlijn(en) en Standaard(en).

Je soussigné, confirme la conformité de l'équipement cité dans la présente à la / aux Directive(s) et Norme(s) ci-dessus  
Ich, der/die Unterzeichnende, erkläre hiermit, dass das oben angegebene Gerät der/den oben angeführten Richtlinie(n) und Norm(en) entspricht.

Il sottoscritto dichiara che l'apparecchiatura di sopra specificata è conforme alle Direttive e agli Standard sopra riportati.

El abajo firmante declara por la presente que el equipo arriba especificado está en conformidad con la(s) directiva(s) y estándar(es) arriba mencionadas.

Eu, o abaixo-assinado, declaro que o equipamento anteriormente especificado está em conformidade com a(s) anterior(es) Directiva(s) e Norma(s)

Date • Data • Date • Datum • Data •

Fecha • Data

Signature • Handtekening • Signature

• Unterschrift Firma • Firma •

Assinatura

Full Name • Volledige naam • Nom et prénom • Vollständiger Name • Nome completo • Nombre completo • Nome por extenso

Position • Functie • Fonction • Position  
• Qualifica • Posición • Função

Producer Address • Adres fabrikant • Adresse du producteur • Anschrift des Herstellers • Indirizzo del produttore • Dirección del fabricante • Morada do fabricante

18<sup>th</sup> April 2023

DocuSigned by:

Ashley Hooper  
B39382C9FD9C478...

Ashley Hooper

Technical & Quality Manager

Fourth Way,  
Avonmouth,  
Bristol,  
BS11 8TB  
United Kingdom

DocuSigned by:

Brendan Denmeade  
D052C5837EB7485...

Brendan Denmeade

Commercial Manager/ Responsible Supplier

15 Badgally Road,  
Campbelltown  
NSW 2560



**apuro**

CW305-A\_A5\_v1\_2023/04/20