

## Technical Specifications ESC-90



ESC-90

### Induction Auto Refill Steam Cabinets

- 30kW rapid induction high-frequency coil technology
- 8 level heat settings with LED visual power display
- 3 gasket sealed door cabinets with locking handles
- Multiple rack positions within each cabinet section
- Control steam volumes released into individual sections
- Automatic water-refill float mechanism
- AISI grade stainless used on all external panels
- High quality engineering and craftsmanship throughout
- Isolated bottom ensures user safety at all times
- Easy to clean and service

### Connections

- Electric - hard wired or fit cable and plug (not supplied)
- Water inlet 1/2" threaded BSP male
- Drain 2" BSP male

### Water Treatment

- Reverse Osmosis (RO) highly recommended in VIC and required in all other Australian states and territories

## INDUCTION

- Ideal for high-volume large-scale Asian style steaming
- 30kW induction produces steam within 5 mins of startup
- Three tiered cabinets with with total max load of 14kg
- Gasket sealed door to lock in steam more effectively
- Automatic water refill mechanism for easy operation
- Lower ambient heat for a more comfortable kitchen
- 90%+ thermal efficiency results in lower energy costs
- Safer than gas with zero carbon emissions or combustion
- Durable, versatile, and easy to clean and service
- 2\* Year Parts and Labour 'Platinum Warranty'

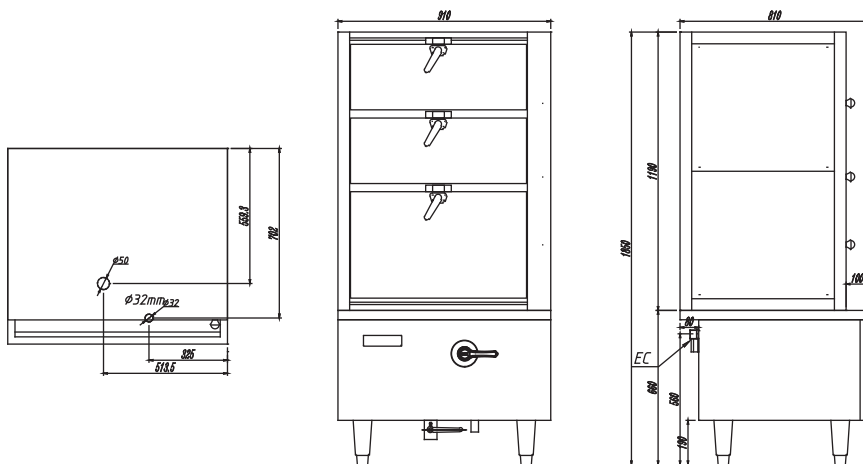

Model	Description	Dimensions	Power
ESC-90	910mm wide Induction 3 Deck Steamer	910w x 810d x 1850h	30kW, 41.7A, 3PH, 50Hz