



Goldstein

800 SERIES GAS GRIDDLE PLATES

GPGDB48-X



Standard features and benefits

- Heavy duty welded stainless steel body for rigidity and durability
- Fully welded surrounds
- 20 MJ griddle burners per every 305mm section
- 20mm thick mild steel griddle plate
- Piezo ignition
- Constant pilot flame, maximises operating and energy efficiency
- Pilot flame failure on burners
- Front grease trough, generous chute and catcher
- Stainless steel fascia and sides, and drip trays for ease of cleaning
- Large, heat resistant reinforced control knob with easy to view settings and high to low flame control
- Adjustable legs 140-170mm
- Easy to service



Other options

- Machined steel or ribbed plates
- 120°C - 280°C thermostatic control
- Bench mounted
- Stand with undershelf



Cert. No.
AGA 7732



MIDDLEBY GOLDSTEIN

1800 013 123 | +61 2 9604 7333
sales@middleby.com.au
middleby.com.au

VIC - TAS - 47 Stubbs Street, Kensington VIC 3031
QLD - U12, 210 Queensport Rd Nth, Murarrie QLD 4172
WA - U2, 9 Meares Way, Canning Vale WA 6155

**HEAD OFFICE
AND MANUFACTURING PLANT**
211-217 Woodpark Road, Smithfield NSW 2164

v1_2024



GPGB48-X

800 SERIES GAS GRIDDLE PLATES

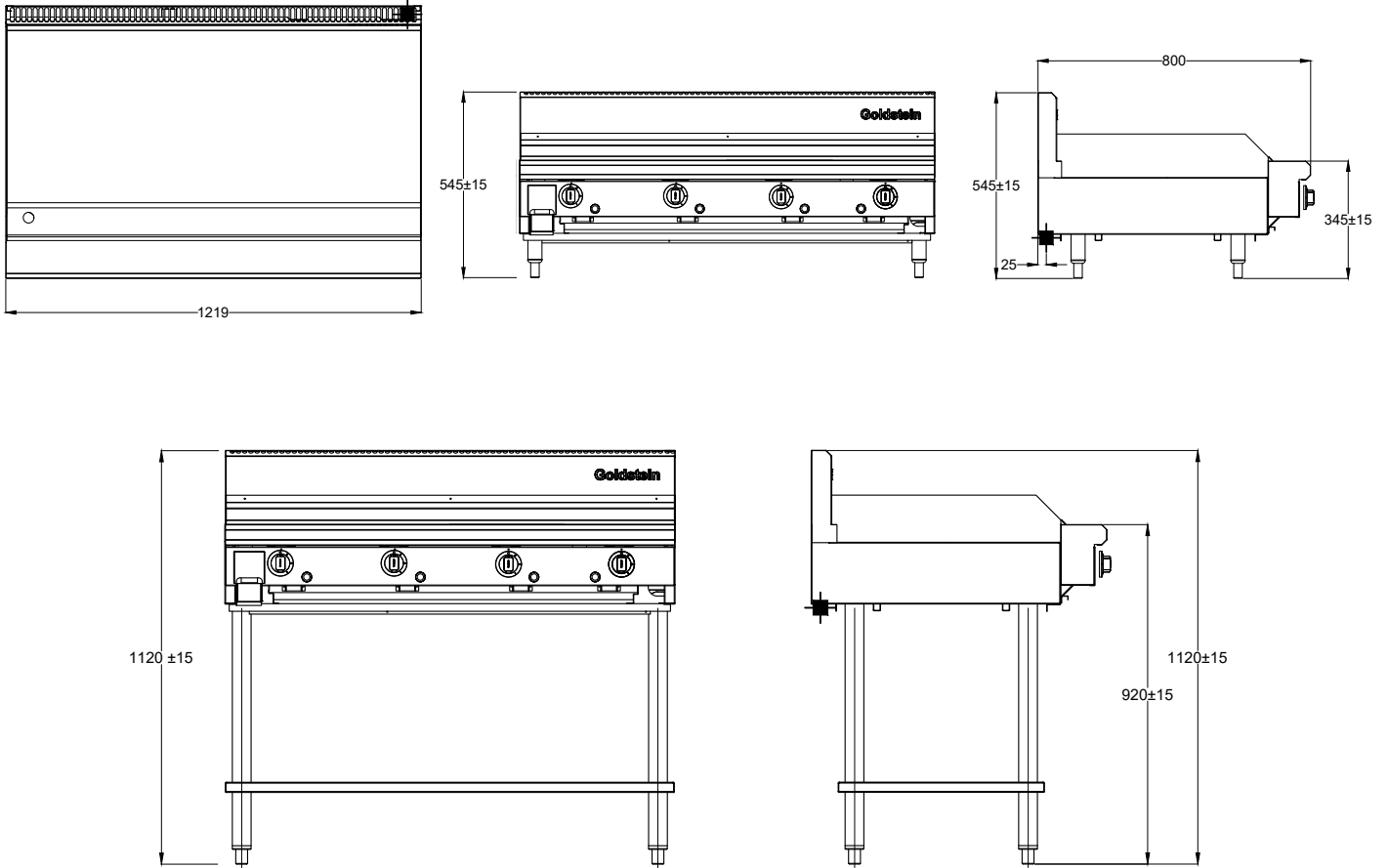

■ 3/4" BSP Gas Connection

SPECIFICATIONS

Dimensions (WxDxH)	bench mounted	1219 x 800 x 545 mm
	on stand	1219 x 800 x 1120 mm
Griddle size		1219 x 520 x 20 mm

Gas connection	3/4" BSPM
Rating NG/LPG	80/80 MJ
Packed dimensions without stand	1280 x 900 x 870 mm

Available in Natural and LP gas

INSTALLATION CLEARANCES (minimum)

Combustible Material	Sides	50 mm
	Back	50 mm

Non-combustible Material	Sides	0 mm
	Back	0 mm

Please note, due to ongoing product development and improvement, we reserve the right to change product design and specification at any time without notice.



1800 013 123 | +61 2 9604 7333
sales@middleby.com.au
middleby.com.au

VIC - TAS - 47 Stubbs Street, Kensington VIC 3031
QLD - U12, 210 Queensport Rd Nth, Murarrie QLD 4172
WA - U2, 9 Meares Way, Canning Vale WA 6155

HEAD OFFICE AND MANUFACTURING PLANT
211-217 Woodpark Road, Smithfield NSW 2164

v1_2024