

# Double Flavour Soft Serve Machine



- PASMO PASCAL -

## S121



GRAVITY



AIR PUMP

### Gravity

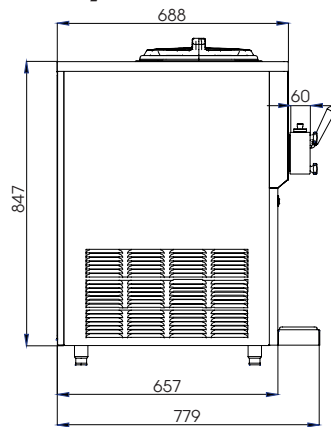
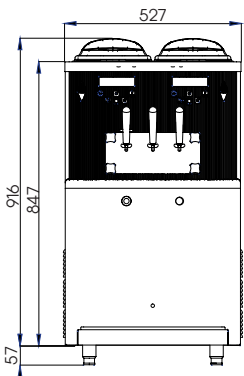

### Air Pump

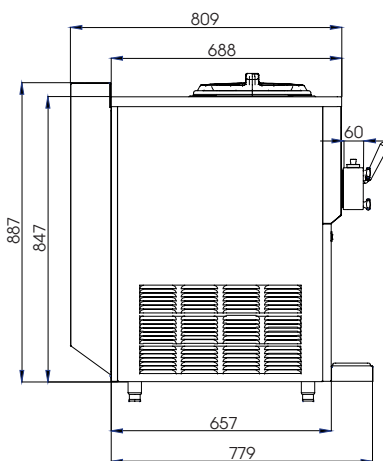
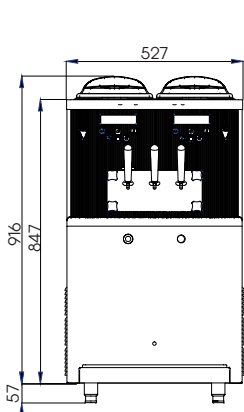

## Features

- Micro-heating auto defrost
- Intelligent Inverter Technology
- Powerful & Compact Design
- Infered Intelligent Sensing
- Low Noise with smooth start-up
- Fast Refrigeration
- Digital Display with Soft Touch controls
- Adustable hardnessfor perfect texture

## Air Pump Model (in addition to Gravity)

- Gear-type air pump system
- 40% increased expansion
- 20% increased production capacity
- Pasteurisation & Cylinder Heating

## Specifications

Overrun (Gravity)	15-40%
Overrun (Air Pump)	35-80%
Hopper Size	2 x 9.5L
Hopper Agitator	Yes
Cylinder Size	2 x 2L
Production/Hr	2 x 40L
Compressor	2 x Embraco/Tecumseh
Pasteuriser	Air Pump Model only
Cylinder Heating	Yes
Defrost	Yes
Refrigerant Type	R404A
Hopper Cooling	Yes
Condensor	Air (Water Optional)
Air Intake	Left & Right
Air Expulsion	Top
Electrical Specs	Gravity: 220V-50Hz, Single Ph Pump: 380V-50Hz, 3 Ph
Power	Gravity: 3.5kW, 16Amp Pump: 3.6Kw, 9.5Amp
Net Weight	168kg (Pump: 250kg)
Packaged Dims.	Gravity: 650 x 1200 x 1010mm Pump: 650 x 1200 x 1010mm
Packaged Weight	185kg (Pump: 275kg)